



# UniGrid® Composite Grid System Configuration Manual

UniQue ■ UniVersal ■ UniGrid®

# UniQue ■ UniVersal ■ UniGrid®

## UniGrid® – A composite grid so revolutionary, we patented it.

The UniGrid® Composite Grid System was introduced during the autumn of 2005. Since then, it has been extremely successful due to its light weight, low thermal mass, and unique modular design, which allow you to configure the system to match your needs. It is presently used in three major processes found in vacuum heat treating: Brazing, Hardening, and Carburizing. The system is in use by major manufacturers in the following industries: gas turbine, power tool, medical, heat exchanger, and contract heat treating.

It is not unusual for our customers to purchase a small system to try it out, then to follow up with an order for additional systems or components once they understand how much this light-weight system can help them. With increasing economic incentives to shorten cycle times, push for higher temperatures, and eliminate heavy and costly

molybdenum or nickel-based alloys from the hot zone, the UniGrid® Composite Grid System is becoming more interesting to an ever wider range of furnace operators.



*Standard UniGrid®  
Composite Grid  
configuration*



*Custom UniGrid®  
Composite Grid configuration*



## Components

The modular design of the UniGrid® Composite Grid system allows it to grow and expand as your needs change. Because of this, we continue to add both standard and custom made components as we find new creative solutions to your problems. Some of these not already shown on the looseleaf detail sheets include:

- Double base (standard) for use with c/c composite runners, special stacking and storage issues
- Centering discs (standard) for use with c/c composite runners
- Unusual leg lengths (custom) from short to tall to optimize your loading density
- Cover sheets (custom) to provide a flat surface with or without holes to assist with heat transfer
- Leg bracing systems (custom) for long separations between layers and heavy loads
- Tubes (custom) for use with double bases to minimize storage space

Please remember, our goal is to help you increase your efficiency by removing thermal mass from your hot zone. This can help increase loads, reduce cycle times, save energy, save time, and increase thruput. We are eager to examine your special needs in detail, and to try to help solve any special problems you may have. Whether we can use standard off-the-shelf components, or if we need custom-made products, we want to help you achieve your goals.

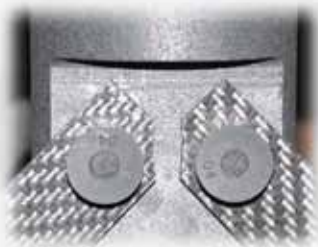

*Leg Bracing Systems*



*Double Base*



*Custom Tube*



*Centering Disc*



*Custom Leg*

*Cover Sheet*



As we have seen, the UniGrid® Composite Grid System offers a wide range of options and configurations to help you achieve your goals of reduced operating costs and greater thruput. As good as the system is, it cannot do everything for everybody. For this reason Schunk also pro-

duces custom fixtures for specialized and high-unit-volume applications. If you have any questions about fixturing for your furnace, please contact your authorized Schunk representative. We are eager to help you improve your processes.

## UniGrid® – Virtually limitless configuration options.

### Inverted Configuration

The inverted configuration is quite similar to the standard configuration described above, except that the entire stack is inverted or flipped upside down. Each layer therefore resembles a traditional table tipped over with a flat top at the bottom and the legs pointing up toward the ceiling. Since the system is stackable, layers can be loaded one at a time until the entire system has been prepared for the furnace. **Figure 3a** shows the most common layout for the bottom layer of a multi-layer inverted configuration system.

**Figure 3b** shows an option for a more heavily loaded system, with a c/c composite runner traversing the underside of the bottom grid, like the gray bars shown in Figure 1, previous page. All layers above the bottom layer must be identical in leg position and layout, however, leg lengths can vary layer by layer if so desired. Although there may be other special needs that dictate the use of an inverted system, the normal reason for doing so is to make the use of ceramic leg rings easier. They can simply be placed over the legs and stacked as needed.

The components needed for such a system can be found in the following table, for a single stack with a 610 x 910 mm. (24" x 36") footprint. Since most systems contain four legs per layer, the table lists the components needed for such a system. If five or six legs per layer are needed, then the corresponding quantities can be adjusted accordingly in the table.

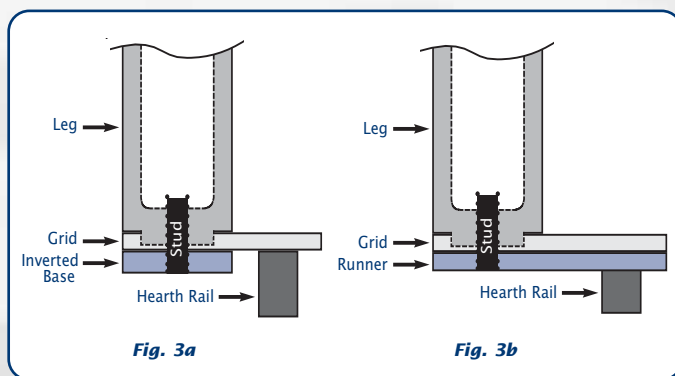

**Figures 3a – b:** Inverted configuration (Fig. 3a) with a common option (Fig. 3b) for bottom layer.

Component	Grid	Inverted Base (underneath grid)	Base	Stud	Leg
Bottom Layer	1	4	0	4	4
Second Layer	1	0	4 underneath	4	4
Subsequent Layers	1	0	4 underneath	4	4
Top Layer	1	0	8 (4 under + 4 on top)	4	0
Total for two layers	2	4	8 (4 under + 4 on top)	8	4
Total for three layers	3	4	12 (8 under + 4 on top)	12	8
Total for four layers	4	4	16 (12 under + 4 on top)	16	12

**Table 2:** Inverted Configuration – 610 x 910 mm. (24" x 36") footprint – 4 legs (one in each corner)

It is important to remember that for any configuration, legs and bases must form a complete column that goes from top to bottom through all layers. Except in very specialized circumstances, you should never have a leg on upper layers that is not directly and completely supported all the way down to the bottom grid or hearth rails.

Don't forget one very handy feature of the system. Wherever you have a base, you can replace it with a ceramic survey ring and nut to make your

system into a survey fixture, or for thermocouple placement during process runs. See the looseleaf detail sheet entitled "Survey Adapters" for more information.

For any questions about configurations and components needed, please contact your authorized Schunk representative. We can provide you with Excel spreadsheets that total up the standard components, and give you both cost and weight for the entire system.

## Overview

This manual is designed as an aid to understanding and designing the best system layout for your unique needs. As a supplement to this manual, there are five looseleaf sheets that list the details of most of the standard components. We will refer to those sheets as we discuss possible system configurations. When thinking about how this system can benefit you, remember to be creative.

## Loading

As we discuss the wide range of possibilities for system layouts, it is important to step back and take an overview of what kind of products and loads you want to accommodate. The UniGrid® Composite Grid is designed to support light to medium loads, to keep costs down. (Heavy loads can be managed with a different and more expensive grid construction. Your authorized Schunk representative will be happy discuss this with you, should it be a better system for your needs.) By using a Finite Element Analysis (FEA) computer program, we can simulate what effects various loads have on the grid. The results of these simulations show a false-color image of the stress patterns and a greatly exaggerated view of the grid deflection (bending due to the load) at a maximum load. The distortion is intentional so it is easier to see, but one must always remember that the visual distortion is far greater (perhaps 50 x) than the actual deflection of the product.

Most furnace operators have had to live with heavy metal baskets of a fixed size for their entire careers. With the UniGrid® Composite Grid System, you now have a whole new range of possibilities and freedoms you did not have before, including adjustability of the distance between layers.

If we simulate a typical 610 x 910 mm. (24" x 36") furnace with the grid placed directly on the hearth rails, it will support a **uniformly distributed load** of 600 kg. (1,320 lbs.) with a maximum deflection of 0.1 mm. (0.004"). See below, left.

If we simulate the same grid placed directly on the two forks of the loading mechanism, each grid will support a **reduced uniformly distributed load** of 400 kg. (880 lbs.) at a maximum deflection of 1.2 mm. (0.05"). The reason for this reduction is that the outer edges of the load are cantilevered too far outboard of the lifting forks. See below.

For single-layer systems, the FEA simulations shown below detail the recommended maximum load for a system with these exact rail and fork dimensions. In this specific case, the lifting fork locations limit the maximum load. A modified lifter with four forks, two outboard of the outermost hearth rails, would eliminate this bottleneck.

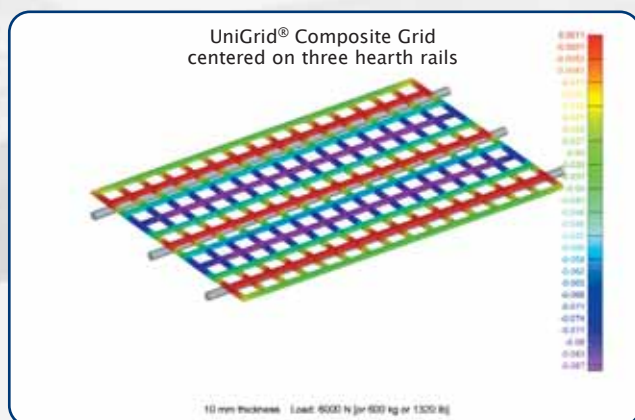

**Grid on Hearth Rails**  
Maximum load = 600 kg. (1,320 lbs.)  
Maximum deflection = 0.1 mm. (0.004")

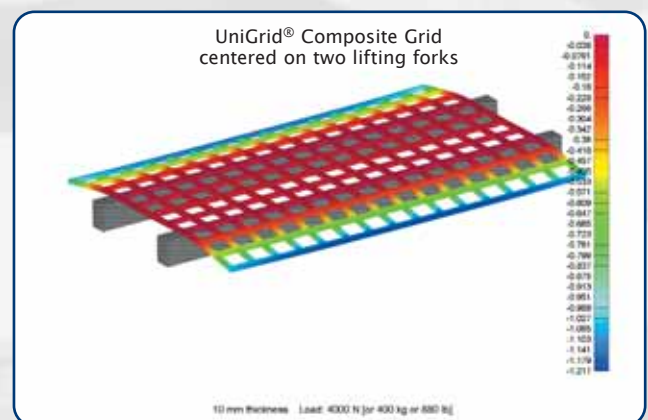

**Grid on Lifting Forks**  
Maximum load = 400 kg. (880 lbs.)  
Maximum deflection = 1.2 mm. (0.05")



# UniQue ■ UniVersal ■ UniGrid®

## UniGrid® – Modular components, customized to your specifications.

With the light weight and compact size of the UniGrid® Composite Grid System, most operators want to use two or more layers to maximize their furnace loading. For multiple-layer systems, each layer is assembled separately and then stacked one on top of the other as the load is built.

A standard leg system utilizing bases, studs, and legs (see loose-leaf detail sheets) is used to accomplish this. Typical configurations and the corresponding maximum uniformly distributed loads and maximum deflections are shown below.

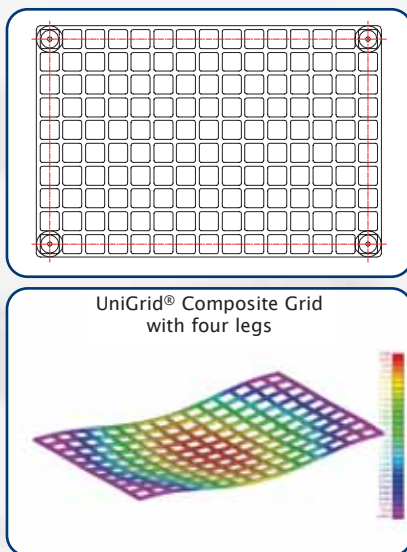

### Loading Layout with 4 Legs/Grid

- FEA simulation greatly exaggerates the deflection in the “Z” direction (up and down) due to the load.
- Maximum calculated deflection is 3.152 mm. (0.124”)
- Suggested maximum **Uniform** load is 102 kg. (224 pounds)
- Non-uniform or point loading will affect this number (probably less but could be more in certain specialized instances)

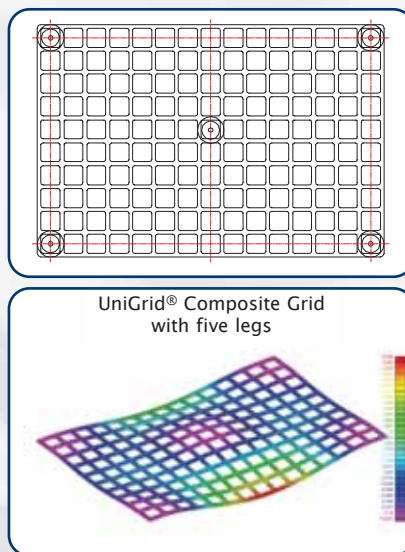

### Loading Layout with 5 Legs/Grid

- FEA simulation greatly exaggerates the deflection in the “Z” direction (up and down) due to the load.
- Maximum calculated deflection is 2.762 mm. (0.109”)
- Suggested maximum **Uniform** load is 204 kg. (448 pounds)
- Non-uniform or point loading will affect this number (probably less but could be more in certain specialized instances)

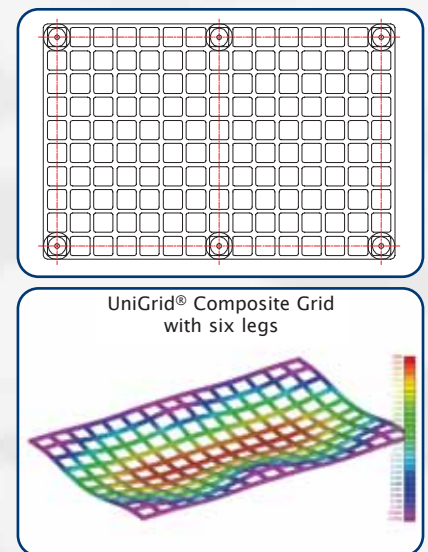

### Loading Layout with 6 Legs/Grid

- FEA simulation greatly exaggerates the deflection in the “Z” direction (up and down) due to the load.
- Maximum calculated deflection is 1.623 mm. (0.064”)
- Suggested maximum **Uniform** load is 306 kg. (673 pounds)
- Non-uniform or point loading will affect this number (probably less but could be more in certain specialized instances)

Since the entire load of each layer is carried downward through the legs, the bottom layer must support the entire stack, including all layers above the bottom layer. This means that in multiple-layer systems, the leg location relative to both the hearth rails and the lifter forks is important. If the legs are located such that the total load from the upper layers is cantilevered too far away from either the hearth rails or the lifter forks, it can result in an overload condition for the bottom grid. This is easily solved by one of three methods or a combination of them: adding legs, changing leg location, or adding a runner under the bottom grid, one that traverses the entire hearth rail and lifter fork system.

To help create the most efficient system for your needs, it is helpful to understand the layout of both the hearth rails and the lifter forks used to load your furnace. For this purpose, we often ask for the dimensions needed to create a map of these components. **Figure 1**, shown to the right, is a map of a 910 x 1220 mm. (36” x 48”) footprint using two UniGrid® Composite Grids side-by-side. The system is six layers tall (12 grids in total) and due to the heavy design load, it required a c/c composite runner underneath the bottom layer to provide additional support.

**For any questions about load capacity, please contact your authorized Schunk representative. We will be happy to assist you.**

## Configurations

With the modular design of the UniGrid® Composite Grid System, there are endless possibilities when it comes to the layout of the system. The most common layouts can be broken down into two categories, the standard configuration and the inverted configuration. Let's examine each of these in more detail.

### Standard Configuration

The standard configuration describes a system built so that all layers except the bottom layer have legs underneath and attached to the grid. Each layer therefore resembles a traditional table with a flat top and the legs underneath. Since the system is stackable, layers can be loaded one at a time until the entire system has been prepared for the furnace. **Figure 2a** shows the most common layout for the bottom layer of a multi-layer standard configuration system.

**Figure 2b** shows an option for a more heavily loaded system, with a c/c composite runner traversing the underside of the bottom grid, like the gray bars shown in Figure 1. **Figure 2c** shows a leg underneath the bottom layer, to assist in moving the lifter forks into position from the loading table. This may or may not be possible due to the furnace construction and relative heights of the hearth rails and heating elements. All layers above the bottom layer must be identical in leg position and layout, however, leg lengths can vary layer by layer if so desired.

The components needed for such a system can be found in the following table, for a single stack with a 610 x 910 mm. (24" x 36") footprint. Since most systems contain four legs per layer, the table lists the components needed for such a system. If five or six legs per layer are needed, then the corresponding quantities can be adjusted accordingly in the table.

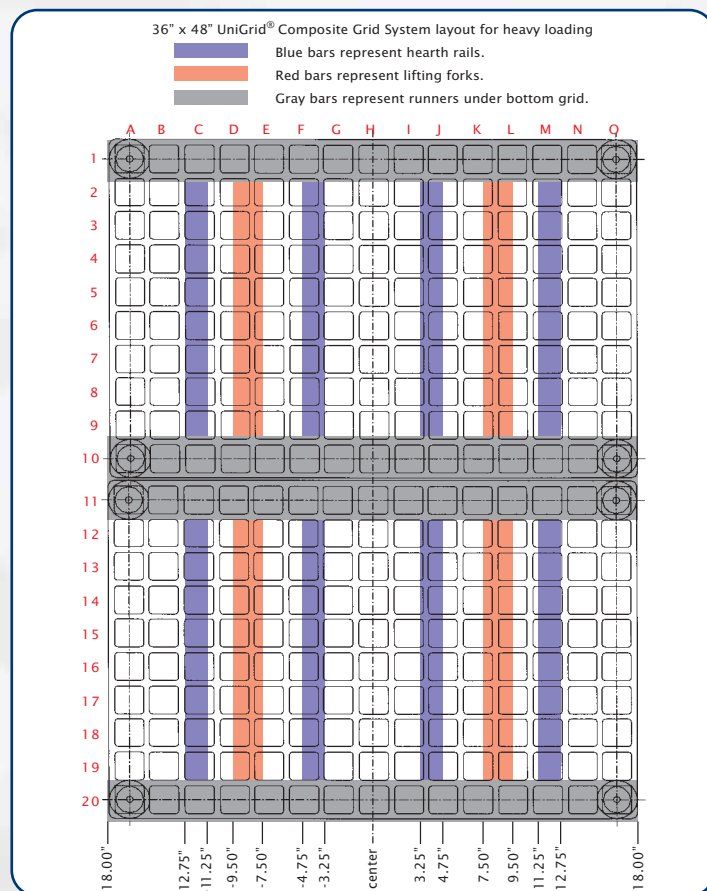
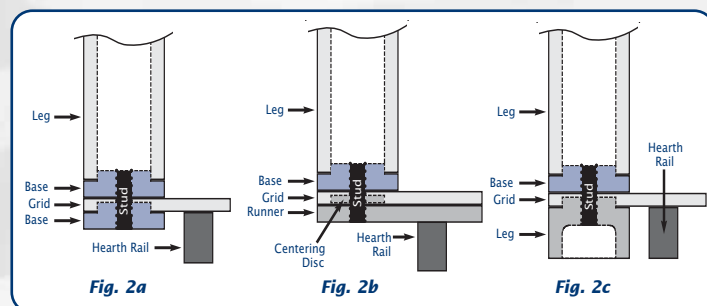

Figure 1: Hearth Rail and Lifter Fork layout



Figures 2 a - c: Standard configuration (Fig. 2a) with two common options (Fig. 2b and 2c) for bottom layer.

Component	Grid	Base (underneath grid)	Base (on top of grid)	Stud	Leg
Bottom Layer	1	4	4	4	0
Second Layer	1	0	4	4	4
Subsequent Layers	1	0	4	4	4
Total for two layers	2	4	8	8	4
Total for three layers	3	4	12	12	8
Total for four layers	4	4	16	16	12

Table 1: Standard Configuration – 610 x 910 mm. (24" x 36") footprint – 4 legs (one in each corner)

In North and South America, contact:

**Schunk Graphite Technology**

Attn: Charles Ego  
W146 N9300 Held Drive  
Menomonee Falls, WI 53051  
U.S.A.

Phone: 262-250-4800  
Toll-free: 888-823-1850  
Fax: 262-255-1391

[unigrid@schunkgraphite.com](mailto:unigrid@schunkgraphite.com)  
[www.schunkgraphite.com](http://www.schunkgraphite.com)

In Europe and Asia, contact:

**Schunk Kohlenstofftechnik**

Attn: Thomas Strobel  
Rodheimer Strasse 59  
35452 Heuchelheim  
Germany

Phone: +49 (0) 641 608-1745  
Fax: +49 (0) 641 608-1673

[thomas.strobel@schunk-group.com](mailto:thomas.strobel@schunk-group.com)  
[www.schunk-group.com](http://www.schunk-group.com)